

LIFE IN THE WOODS.

RESIN PRODUCTS

Our goal is to develop products with zero waste

By combining resin with wood discarded as worthless by the market, we strive to create new value and pursue responsible product development

- ・丸紅木材株式会社
- ・MARUBENI LUMBER VIETNAM CO., LTD.



RESIN X WOOD

MARUBENI LUMBER VIETNAM CO., LTD.

We carry out a fully integrated process from material procurement to manufacturing

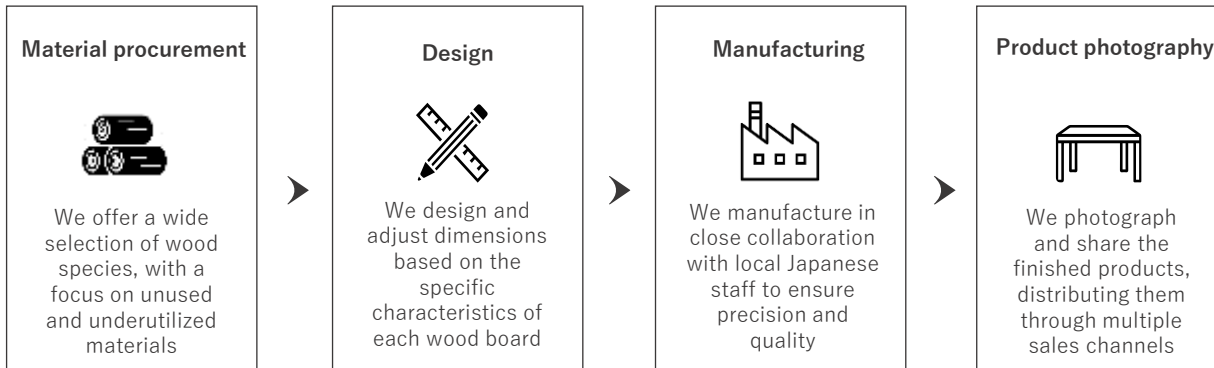

Since August 2023

We have adopted renewable energy initiatives

With the goal of reducing CO₂ emissions and producing environmentally friendly products, we started using solar power for production

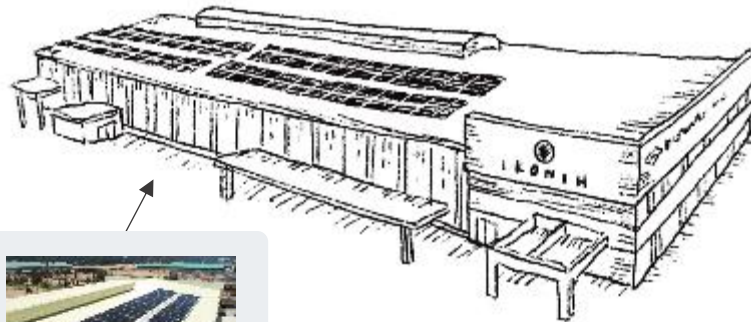

Factory Certification Information

- ✓ ISO 9001 Certification
- ✓ FSC Certification (A000504)



About the advantages of production in Vietnam (MBL VIETNAM)

Resin

Procurement of affordable resin

Achieving full transparency can be challenging; therefore, we recommend adding a slight tint to enhance the appearance

Price Estimate (Including Hardener)

Vietnam ... 15\$/kg

Japan ... 50\$/kg



Frame

Manufactured in Vietnam

Vietnam is both a major producer and consumer of steel, ensuring reliable sourcing of arm components. We offer a range of user-friendly standard models to meet diverse needs.

Price Estimate

Vietnam ... 19.5\$/1set

Japan ... 39\$/1set

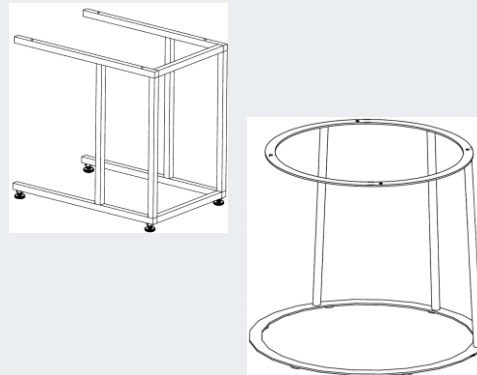

Clock movement

Equipped with Japanese-made parts

Equipped with a high-quality SKP movement made by Seiko Time Creation Inc., this product ensures quiet and reliable operation with its silent-sweep second hand



Construction of a production line

Optimization of the drying process

Drying racks are installed customized to the size of each unit, maximizing space to accommodate drying 5 to 10 sheets simultaneously



About factory facilities and equipment

Workroom and production line

Equipped with dedicated air conditioning, dust, and particle control measures for resin product production to prevent defects and improve productivity

Point.1

Install dedicated racks for each workstation to eliminate dead space caused by resin curing time

Point.2

To prevent dust and particle intrusion, the air pressure is maintained at a high level, and dust extraction ducts are installed

Point.3

Automate resin stirring, pouring, and product photography to improve efficiency

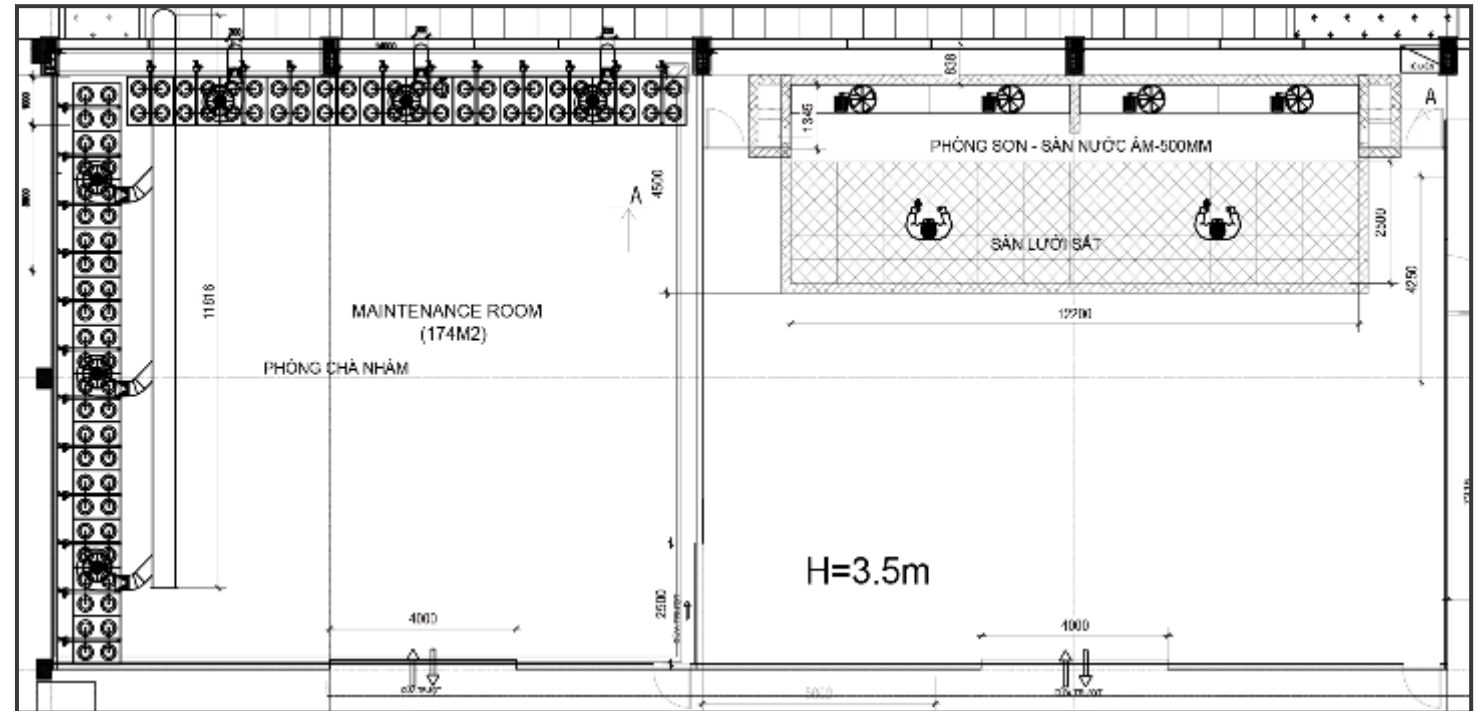

About factory facilities and equipment

Tools and equipment

Rough machining is performed using shared furniture processing equipment available on-site, including planers, crosscut saws, table saws, panel saws, sanders, and more

| | |
|--------------------------|---|
| Cut | Panel saw, table saw, crosscut saw |
| Surface finishing | Polisher, disc grinder, manual sander, router (chamfering machine) |
| Others | Vacuum deaeration equipment, heat gun, burner, spray gun for painting, etc |
| Consumables | Formwork materials (film-faced plywood, solid wood), OPP film, plastic wrap, silicone, paint, etc |



About Resin Clocks (Wall Clocks)



- **Side**
Standard is approximately 3R processing level
- **Size**
300 x 300 x T20 mm (Basic size)
- **Weight**
Approximately 1300 g
- **Options**
Laser processing, etc
- **Suggested Retail Price**
90\$(excluding tax and shipping)